

# **SUPER-FLEX CA3 SERIES LOADERS INSTALLATION AND OPERATION MANUAL**



Advanced Auxiliary Equipment, Inc.  
POB 810  
Cobbs Creek, VA 23035  
(800) 918-5820

CA3 31611

# Series 3 Loaders

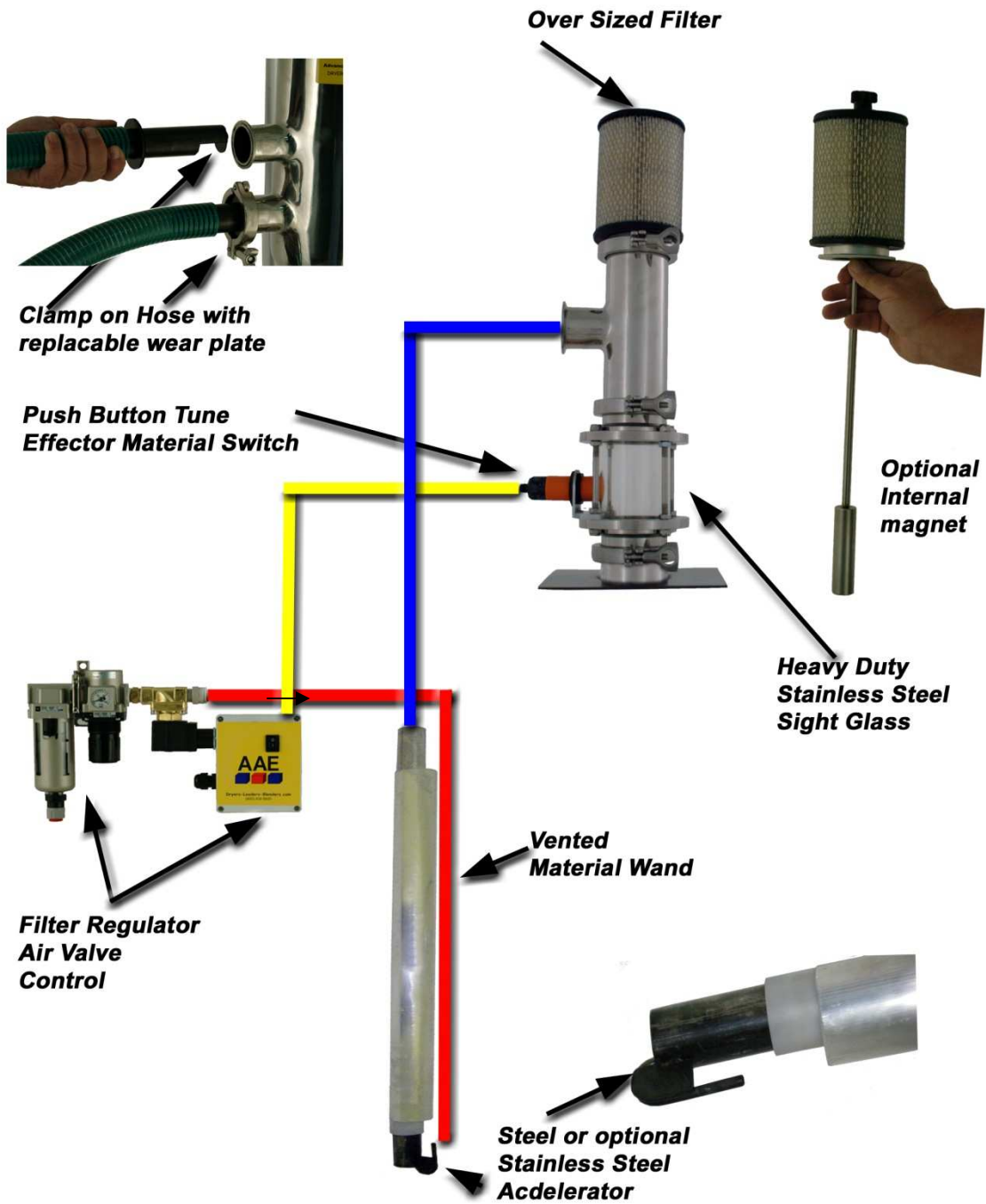

## **PRINCIPALS OF OPERATION**

Compressed air is directed to the accelerator on the bottom of the material wand. The accelerator creates a strong airflow that draws material into the wand and blows it to the receiver. Once in the receiver the material falls into the sight glass and the air exits via the air filter. The load cycle is initiated by the level switch and continues until the switch signals full.

## **INSTALLATION INSTRUCTIONS**

1. Mount compressed air filter regulators on a secure mounting surface within 10 feet of both material sources and the level switch.
2. Securely mount the receiver on the machine flange or magnet.
3. Connect flex hose to the wands and the receiver inlets. Secure with hose clamps.
4. Install material level switch on the sight glass in the top position. Connect switch to control with supplied cable.
5. Connect 3/8 inch compressed air hose to the solenoid valves and accelerators. Slide the compressed air hose inside the vent tube on the material wand and over the accelerator tube on the bottom.
6. Set Compressed air pressure at 50 PSI to start.
7. Make sure that system is properly grounded. Monitor for presence of static electricity and ground system to prevent discharge.

## **OPERATING INSTRUCTIONS**

Do not jam wands into material. They will draw into the material as they start to load. If material fails to flow pull the wand out slightly and flow will start again.

Adjust compressed air pressure as needed for good conveying. Compressed air pressure normally will be between 40 and 80 PSI. Lower compressed air consumption by operating at the lowest compressed air pressure that result in reliable material transfer.

Extend control relay life by reducing material cycling and filter pulse to minimize cycles.

### **General Maintenance**

Super-Flex Loaders require inspection and observation to prevent failure. Inspect the following items as needed. If defects or potential contamination is observed discontinue use until repaired.

**Filters** – Filters fail due to imbedded particles over time. The smaller the particles being conveyed the shorter the filter life will be. Moisture also can cause premature filter failure. The filter should be clean at all times. Clogged filters waste compressed air and eventually cause loading failure. Inspect filters on a regular basis and clean as necessary. Clean by blowing compressed air from the outside of the filter toward the center. Wear proper safety equipment, including eye protection, when cleaning with compressed air. If filter cannot be cleaned replace the filter as needed. Inspect filter for wear and possible contamination and replace as necessary.

**Compressed Air Filter** – The useful life of the compressed air filters is dependent on the quality of the supplied compressed air. Check compressed air filters and replace as needed.

**Flex Hose** – Inspect Flex Hose for wear and possible contamination as needed. The life of Flex Hose will be less with abrasive material. Check for contamination in Flex Hose caused by material. Replace and repair flex hose as needed.

**Gaskets and Seals** – Make sure gaskets and seals are properly installed. Inspect as needed for wear and replace as needed.

**Material Deflector and Clamped Hose Tube** - Inspect for wear as needed. If wear is observed replace.

**Material Wand and Accelerator** – Inspect Material Wand and Accelerator for wear and possible contamination as needed. The life of Material Wand and Accelerator will be less with abrasive material. Check for contamination in Material Wand and Accelerator caused by material. Replace and repair Material Wand and Accelerator as needed.

### Static Electricity

Static electricity can be generated during conveying plastic materials. Some material can generate dangerous levels of static electricity. Monitor the conveying system for the presence of static electricity. If static electricity is present ground the system too adequately to provide safe operation.

### Optional Air Saver Timer AST

The air saver timer can save up to 30% of the compressed air consumed by reducing the number of load cycles. Without the air saver timer the loading cycles with the switch consuming a large amount of air starting and stopping the material flow. After the material switch is satisfied loading continues for an adjustable period from .3 to 10 seconds. The time should be set long enough to fill the receiver up near but up to the material inlet. 4 seconds is a good time to start with.

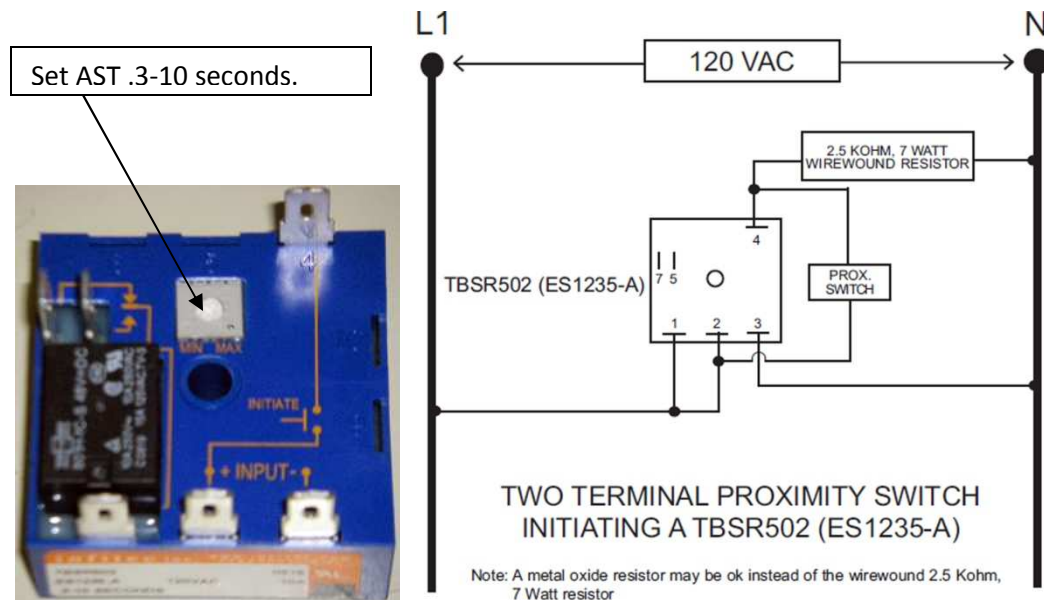

## SETTING MATERIAL SENSOR

**Note – ANY TIME YOU PRESS EITHER SWITCH LESS THAN 3 SECONDS YOU WILL RESET THE SWITCH!**

This means that if you release the button before 3 seconds when you are teaching you will reset the switch. When teaching wait until the LED blinks fast to release. Time starts when you press the button – not when the LED starts to blink.

### Reset or Set to Normally Closed

Press OUT/ON button until LED blinks twice – not more than 5 seconds

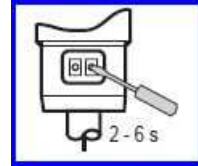

### Teach Full State

Fill material to just above sensor. Press OUT/OFF until LED blinks fast – not less than 3 seconds.

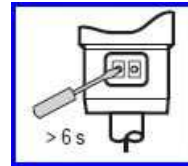

### Teach Empty State

Make sure material is below switch. Press OUT/ON button until LED blinks fast – not less than 3 seconds.

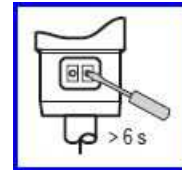

### Setting Lock

Lock and unlock settings to prevent adjustment. Press OUT/ON and OUT/OFF buttons together for more than 10 seconds.

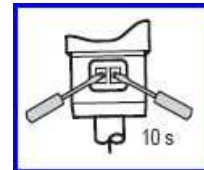

## TWO WIRE DIAGRAM

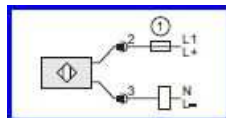

## Trouble Shooting Guide

Problem	Cause	Solution
Not Loading No Compressed Air	No control signal	Identify and repair
	No Compressed Air	Identify and repair
	Failed Valve	Identify and repair
	Level Switch	Adjust or replace
Not Loading Compresses Air Present	Clogged Filter Loader	Clean or replace
	Clogged Filter compressed air	Clean or replace
	Clogged Accelerator	Clear
	Excessive Load Time	Reduce load Times
	Incorrect deflector position	Turn deflector to down position
Reduced Rate	Low air pressure	Increase air pressure
	Clogged Filter Loader	Clean or replace
	Clogged Filter compressed air	Clean or replace

### Warranty

AAE will repair or replace any part that fails due to defective workmanship or use in accordance with the operation manual and not limited or excluded for a period of five years. Liability is limited to repair or replacement of the defective part at the option of the company.

### Warranty Limits and exclusions

The following causes of defect are excluded from warranty:

- Failure to comply with instructions included in manual.
- Abuse or misuse
- Change of ownership

The following are limits to warranty:

- Filters – warranty is limited to defects in workmanship or material reported within 60 days of invoicing.
- Flex Hose - warranty is limited to defects in workmanship or material reported within 60 days of invoicing.